

This document contains the proprietary information of Tandemloc, Inc. and your access and use shall be, and is at all times, pursuant to and limited by the Tandemloc, Inc. Terms of Use. You shall not, and shall not encourage, assist, or authorize another party to copy, distribute, publicly display, modify, reverse engineer, decompile, or take any other action to reproduce this document or the information contained herein.

©2019 by Tandemloc, Inc.

Dimensions are subject to manufacturing tolerance and change.

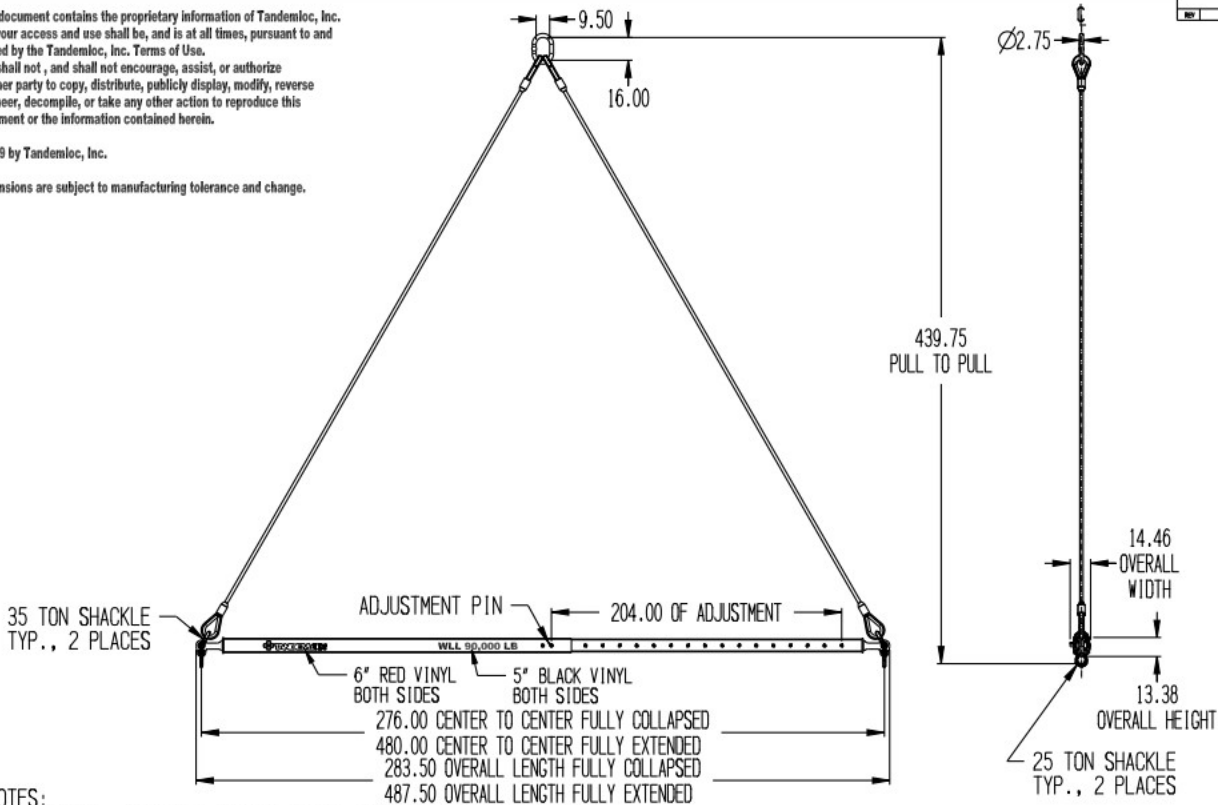

NOTES:

- PART NO.: AT14A090-480-PA, 276"-480" TELESCOPIC SPREADER
 AT14A090-480SPA, 276"-480" TELESCOPIC SPREADER WITH TOP SLING
 AT14A090-480WPA, 276"-480" TELESCOPIC SPREADER WITHOUT SHACKLES
- WLL: 90,000 LB. @ 60° MINIMUM
- PROOF TESTED TO 125% (112,500 LB.) AND CERTIFIED
- STANDARD SPECIFICATION # EAD21000A APPLIES
- FINISH: SANDBLAST AND PRIME AND PAINT YELLOW
- CALCULATED WEIGHT: 2,268 LB. SPREADER WITH SLING; 2,956 LB. SPREADER W/OUT SHACKLES; 2,096 LB.
- DESIGNED AND MANUFACTURED TO MEET OR EXCEED ASME B30.20 AND BTH-1, DESIGN CATEGORY B, SERVICE CLASS 0.

** DO NOT SIGN IF CHANGES ARE REQUIRED **

CUSTOMER APPROVAL: _____

DATE: _____

<small>UNLESS OTHERWISE SPECIFIED: UNLESS OTHERWISE NOTED, DIMENSIONS ARE IN INCHES & TOLERANCES ARE: .125" ±.015" .125" ±.015" .125" ±.015"</small>	<small>UNLESS OTHERWISE SPECIFIED: UNLESS MAX. ORDERING TEL. IS: 0 TO 4" ±.015" 4.014" TO 7" ±.020" 7.021" TO 30.5" ±.040" OVER 30.5" ±.060"</small>		
		AT14A090-480-PA 276"-480" TELESCOPIC SPREADER	
<small>THIS DOCUMENT CONTAINS PROPRIETARY INFORMATION OF TANDEMLOC, INC. REPRODUCTION OR DISTRIBUTION WITHOUT THE WRITTEN AUTHORIZATION OF TANDEMLOC, INC. IS EXPRESSLY PROHIBITED.</small>	<small>APPROVALS</small> DATE: 07-16-19	<small>REV. DATE</small> D 65059	<small>REV. DATE</small> SAT14A090-480-PA - SHEET 1 OF 1